



P H O E N I X

COOKE BROTHERS

INTERLEAF HINGES

UNIQUE SLIMLINE
HINGE SOLUTION

INTERLEAF HINGES

UNIQUE SLIMLINE HINGE SOLUTION

The INTERLEAF Continuous Hinge from Phoenix

Recognising the growing demand for a minimal gap between the frame and door profile, the PHOENIX INTERLEAF continuous hinge has been specifically designed to meet this requirement.

The innovative features of the Phoenix Interleaf hinge uniquely combines the strength of continuous fixing points along the entire length of the door, with the benefit of anti-finger trapping on the knuckle side, coupled with an aesthetically stylish and a streamlined sightline, purposely designed to enhance and compliment the visual appearance of any doorset.

Standard full height heavy duty continuous hinges typically need a clearance gap of 12mm whereas the INTERLEAF hinge will sit directly on to the door and frame and will only take up 3mm (excluding Intumescent if used on a fire door).

The unique design of the INTERLEAF Continuous Hinge ensures that door and frame preparation times can be significantly reduced as there is no rebating required, the INTERLEAF hinge is also well suited for use in situations where door / frame repair is required as it can easily be fitted in place of existing hinges without the need for significant modification.

Incorporating the Phoenix maintenance free polymer bearings the INTERLEAF Continuous Hinge is fully tested to BS EN1935 Grade 14 (160Kgs) and CE marked. Compatible with a wide range of door thicknesses including 44mm and 54mm timber and steel doorsets. Intumescent kits are also available for use on Fire Doors.

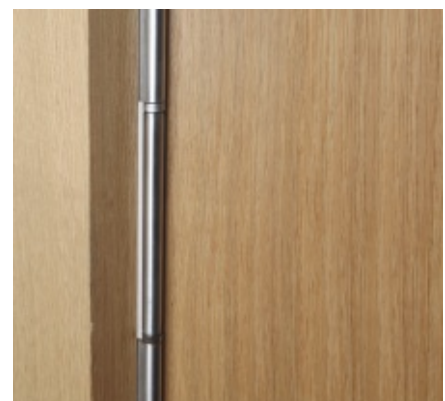



Reduced Ligature and Mental Health applications

The INTERLEAF Continuous Hinge has been extensively specified for use in situations where there is a perceived or actual risk of self-harm including hospitals and Mental Health facilities, its unique design provides a strong and robust hinging solution whilst maintaining an aesthetically pleasing design. By utilising the purpose made end caps the risk of creating a ligature point is significantly reduced.

Typical Applications

Hotels
 Hospitals and mental health
 Home
 Gym
 Conference and exhibition centres
 Public buildings
 Educational establishments

- Manufactured in Grade 304 and 316 Stainless Steel
- Standard Length 2134mm (Bespoke lengths can be supplied to order)
- Fully tested to BS EN1935 Grade 14 (160Kgs) and CE marked
- Integrated Maintenance Free Polymer Bearings
- Purpose made End Caps available to reduce Ligature opportunity
- Anti-finger trapping on the knuckle side of the hinge
- Finish – Satin polished as standard
- This hinge has been accepted for Community Design Registration (CDR) proving that it is a unique and innovative design.

INTERLEAF HINGES



Dimensions

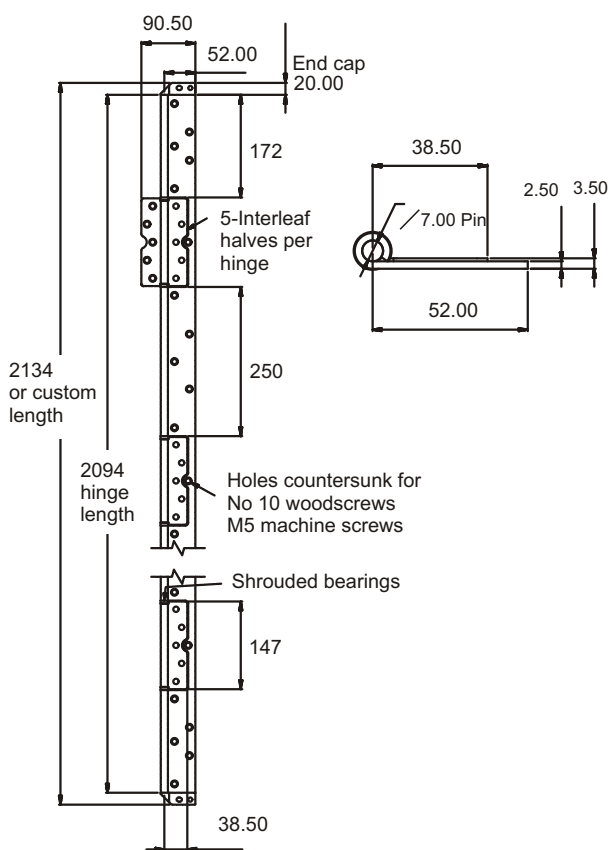

Illustrated 56135RL for 44mm (minimum) doors with reduced ligature end caps

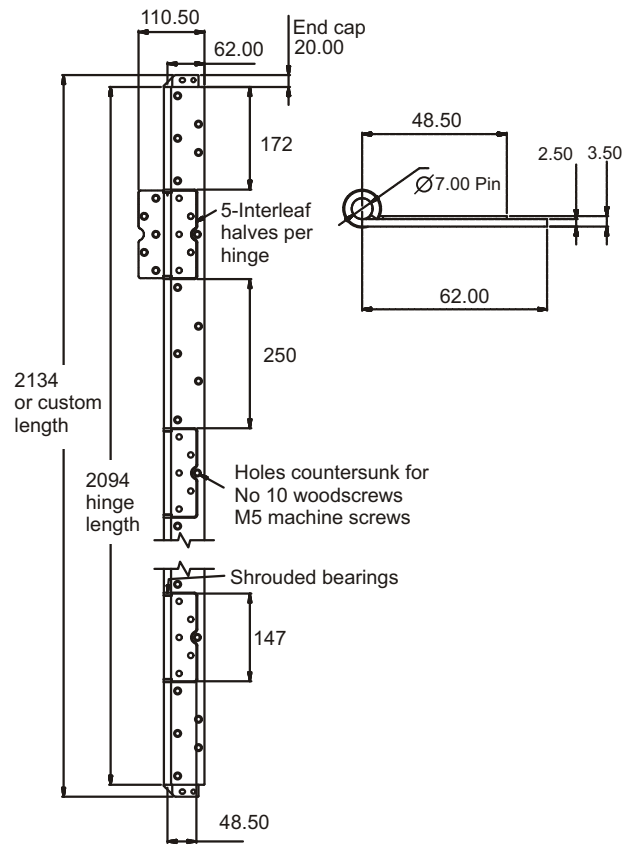

Illustrated 56152RL for 54mm (minimum) doors with reduced ligature end caps

INTERLEAF Continuous Hinge

56135 2134mm x 52mm (to suit minimum 44mm door)

56152 2134mm x 60mm (to suit minimum 54mm door)

Reduced ligature INTERLEAF Continuous Hinge

56135RL 2134mm x 52mm (to suit minimum 44mm door)

56152RL 2134mm x 60mm (to suit minimum 54mm door)

- Fully tested to BS EN1935 Grade 14 (160kg)
- CE Marked – cert no AC5005
- Suitable for use on fire doors FD30 and FD60
- Tested and approved Grades 1 to 4 to the DHF technical specification TS001 for door mounted anti-ligature devices

Cooke Brothers INTERLEAF hinge is suitable for use on Fire Doors, however to ensure full compatibility please specify the recommended INTERLEAF intumescent pack when ordering. It is also recommended that in addition to the INTERLEAF intumescent pack, standard Fire/Smoke seals are used as part of the overall doorset assembly, please contact Cooke Brothers Sales Team for further information and technical support.

Available in Stainless Steel (Grade 304 and 316) and in standard lengths of 2134mm (other lengths available to order).

Phoenix INTERLEAF Continuous Hinges are subject to Community Design Registration (CDR)

COOKE BROTHERS

Technical Sales: Phone: 01922 740011 Fax: 01922 740003 ©2014 Cooke Brothers Ltd.
Email: sales@cookebrothers.co.uk Website: www.cookebrothers.co.uk